

3703

110° Snap-On 3000 Series



- Heat tempered, all-metal construction
- Three-dimensional adjustment in hinge arm
- Automatic, smooth-closing design for minimal abrasion and wear
- Accommodates overlays up to 21mm (26/32")
- Reduces door installation time by 50%
- Undue stress absorbed through self-tightening action

3703/3704 Minimum Reveal (measured in millimeters)

Cup drilling distance	Door thickness									
	16	17	18	19	20	21	22	23	24	
3.0	1.4	1.7	2.0	2.2	2.6	2.9	3.9	5.3	6.7	
3.5	1.4	1.7	1.9	2.2	2.5	2.9	3.4	4.8	6.2	
4.0	1.4	1.7	1.9	2.2	2.5	2.9	3.2	4.3	5.7	
4.5	1.4	1.6	1.9	2.2	2.5	2.8	3.2	3.8	5.2	
5.0	1.4	1.6	1.9	2.1	2.5	2.8	3.1	3.6	4.7	
5.5	1.4	1.6	1.9	2.1	2.4	2.8	3.1	3.5	4.2	
6.0	1.4	1.6	1.9	2.1	2.4	2.7	3.1	3.5	3.9	

Ordering Information

Packaging:

300 pieces

(50 pieces per interior box)

*300 bulk

For baseplate selection, refer to pages 64-66.

IMPORTANT

To determine the correct application, Grass strongly recommends a trial mounting for all hinges and baseplates.

	Screw-On Hinge Cup		Dowelled Hinge Cup	
	Description	Item #	Description	Item #
3703 Overlay	- self-closing	3703 VS	3703 VS8	70039-34
	- self-closing		3703 VS8-45	27837-15*
	- free-swinging	3713 VS	3713 VS8	11157-34
3704 Half-Overlay	- self-closing	3704 VS	3704 VS8	55413-34
	- self-closing		3704 VS8-45	27838-15*
	- free-swinging	3714 VS	3714 VS8	55414-34
Cover Cap	3703 (black plastic)	12350-41	Packaging: 50 pieces (Imprinting available)	
	3703 (nickel plastic)	12351-41	Packaging: 50 pieces (Imprinting available)	
	3704 (black plastic)	55409-41	Packaging: 50 pieces (Imprinting available)	
	3704 (nickel plastic)	55410-41	Packaging: 50 pieces (Imprinting available)	

VS = vertical steel cup, VS8 = vertical steel cup with two 8mm dowels, VS8-45 = vertical steel cup with two 8mm dowels in 45mm boring pattern

3703 Overlay

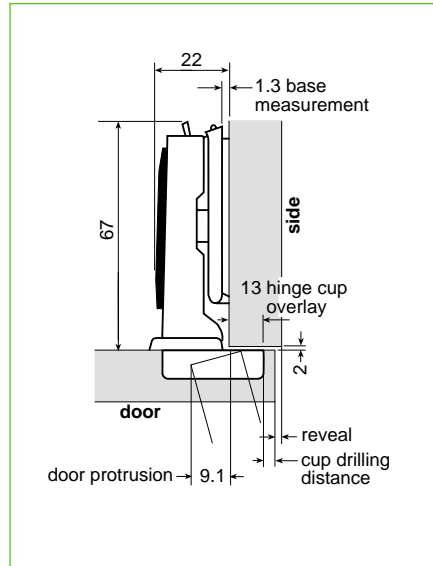

3704 Half-Overlay

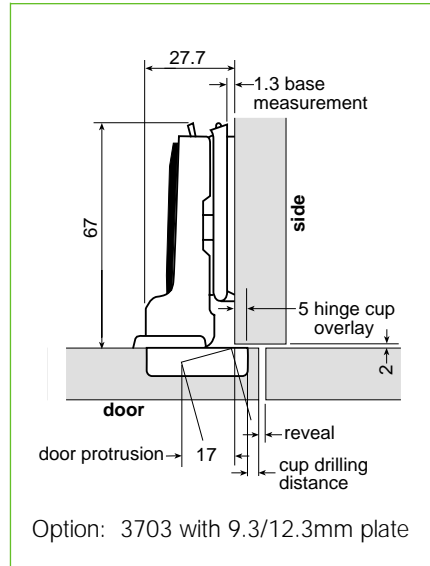

3704 Inset

using 12.3mm Baseplate

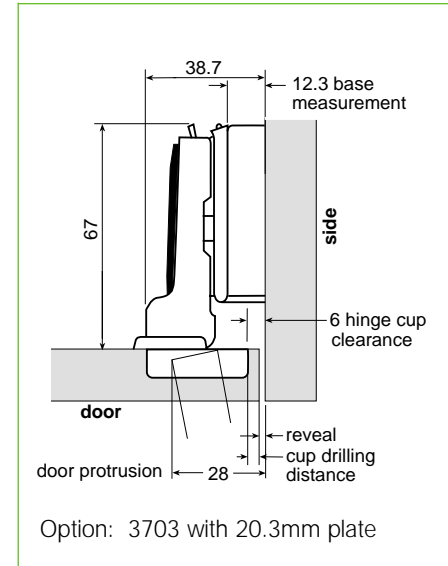

Maximum Door Thickness and Overlay

Maximum Door Overlay: 19mm (3/4") in neutral position on a 1.3mm base-plate.

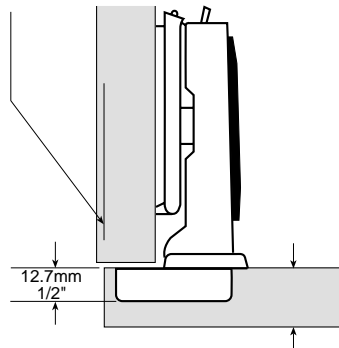

Maximum Door Thickness:
16mm (5/8") - 22mm (7/8") overlay
16mm (5/8") - 19mm (3/4") inset

Cup Drilling

Cup Drilling Depth: 12.7mm (1/2")
Cup Drilling Distance: 3mm (1/8") to 6mm (1/4"), depending on end panel thickness and overlay desired.

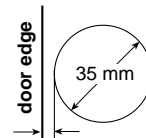

Hinge Adjustments

- ① Side Adjustment +/-2mm
- ② Depth Adjustment ... +/-2mm
- ③ Height Adjustment . +/-2mm

Note: Use a POZIdrive screwdriver for hinge adjustment.

Fastening Screws #6 x 5/8" FHP

